



HÖFLER

**SPEED
VIPER**

CYLINDRICAL GEAR TECHNOLOGY – GRINDING MACHINES



KLINGELNBERG

Innovative Cylindrical Gear Machining for Flexible Requirements

All around the world, manufacturers of gears and gear-boxes ensure their leading edge in gear machining with innovative, advanced technology by KlingelInberg.

The [Höfler Cylindrical Gear Technology](#) division allows users to manufacture cylindrical gears with diameters from 20 millimeters up to 10 meters economically and with high precision. Moreover, thanks to decades-long expertise and great innovative strength, KlingelInberg is able to maintain a leadership position not only through its high research and development standards, but also its in-house application engineering services.

KlingelInberg offers advanced technology and efficient machines for cylindrical gear manufacturing. The company sees itself as a solutions provider that supports its customers from gear design to quality assurance, in order to produce top quality gearing. KlingelInberg's software system for production management from process design to quality control is called [Closed Loop](#) – and is now also available for cylindrical gears.

Its core component is the powerful duo, [Gear Designer](#) and [Gear Operator](#) – two newly developed software solutions that accurately simulate the entire manufacturing process using a digital twin of the workpiece to be ground, providing optimal support for gear design and manufacturing.

Höfler cylindrical gear machines are developed with real-world applications in mind and satisfy a whole host of application industry requirements. Customers include all gearbox manufacturers in the precision engineering, aviation and automotive industries, as well as manufacturers of large gears for the energy industry.



Winner of the iF Design Award 2018

HÖFLER cylindrical gear generating grinding machine Speed Viper 180

Exceptional Concepts in the Gearing Process

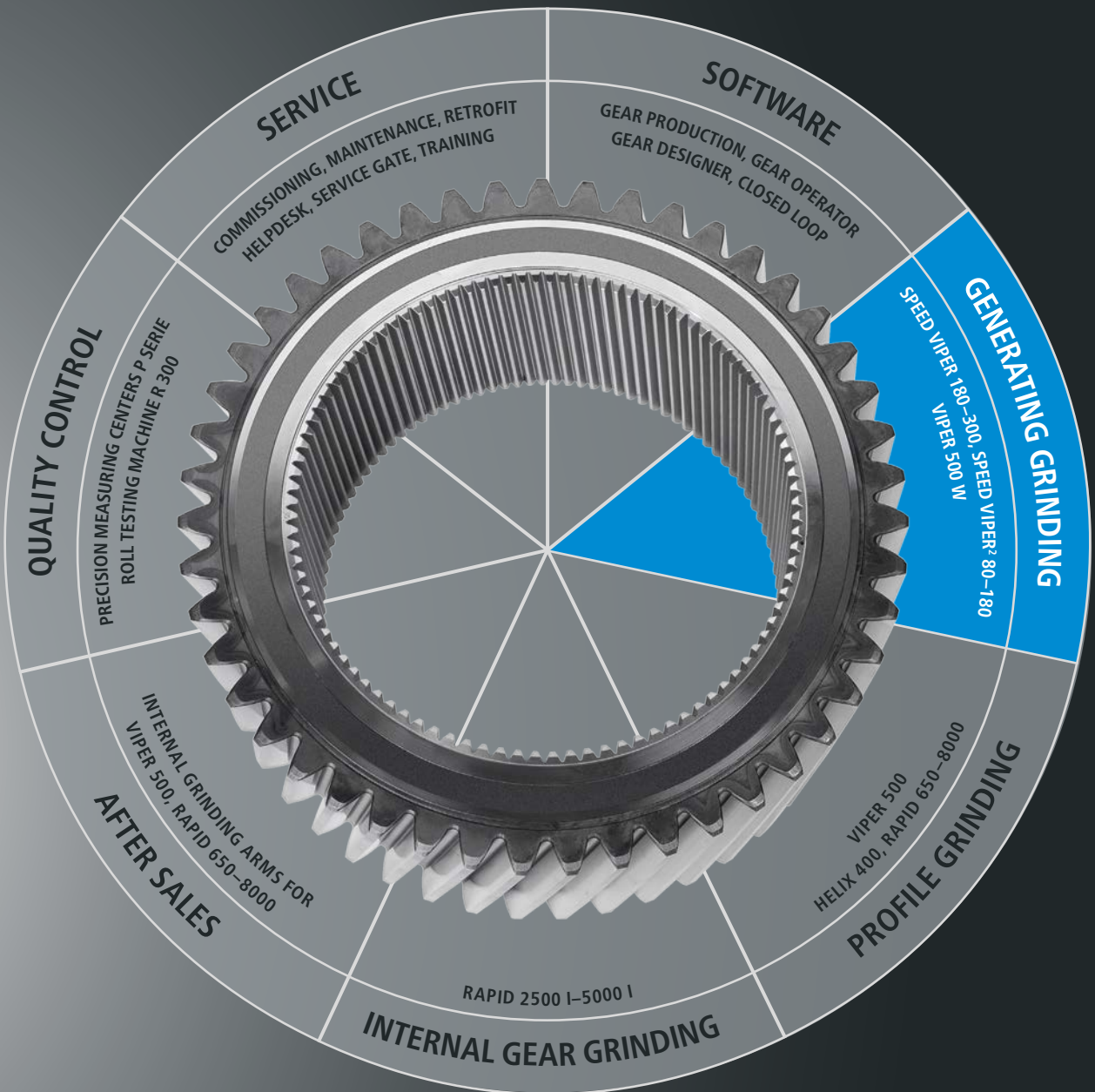

The New Force in High-Productivity Generating Grinding

The Höfler cylindrical gear grinding machine Speed Viper – which focuses on high-productivity generating grinding in large-series manufacturing – draws on the successful concept of the Viper 500 series. It is available in four different configurations based on individual requirements: **Speed Viper 300 and 180 in a single-spindle configuration**, as well as **Speed Viper² 180 and 80 in a dual-spindle configuration**. Depending on the model, Speed Viper is designed for maximum workpiece diameters of 80, 180 and 300 mm. In addition to gears, it can also grind extra-long shafts. This is possible thanks to a distance between centers over table of up to 1,100 mm.

The Speed Viper² dual-spindle concept achieves minimal auxiliary times, fulfilling the productivity requirements of the automotive industry. The grinding worms, with an outside diameter of 320 mm and a width of 200 mm, ensure a long tool life. An automatic tool clamping system with an integrated balancing unit also contributes to shortened tooling times. In addition, the Speed Viper with partial or full automation can be equipped with an automation interface that meets the VDMA 34180 standard.

The **Gear Operator** machine software and a **process-oriented navigation system via wizard technology** make operation easy, even in the most complex applications. And last but not least, ultra-modern drive and control technology guarantees maximum energy efficiency.

- Highly productive generating grinding thanks to intelligent machine software and a robust machine base
- Large component range to 300 mm workpiece diameter and 1,100 mm workpiece length
- Long tool life thanks to large tool diameters of 320 mm and a tool length of 200 mm
- Minimal auxiliary times
- Short set-up times thanks to automatic tool clamping system
- Flexible automation concept
- Innovative operating concept
- Optimal energy efficiency (e²)

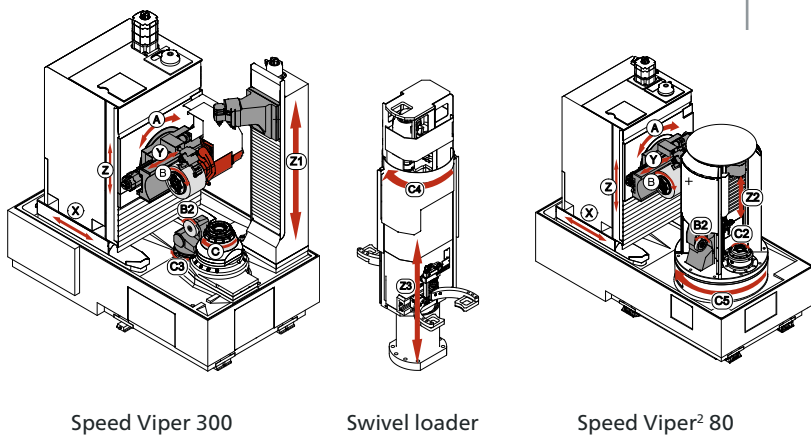

Speed Viper 300

Swivel loader

Speed Viper² 80

CNC axes

Speed Viper 300/180

X	Radial axis
Y	Shift axis
Z	Stroke axis
Z1	Counter support
A	Swivel grinding head
B	Grinding spindle
B2	Dressing spindle
C	Workpiece spindle
C3	Dressing device swivel
C4	Loader swivel
Z3/Z4	Loader stroke axes

Speed Viper² 180/80

X	Radial axis
Y	Shift axis
Z	Stroke axis
Z1/Z2	Counter support
A	Swivel grinding head
B	Grinding spindle
B2	Dressing spindle
C1/C2	Workpiece spindle
C5	Rotating tower

Speed Viper – More Than Just a Generating Grinding Machine

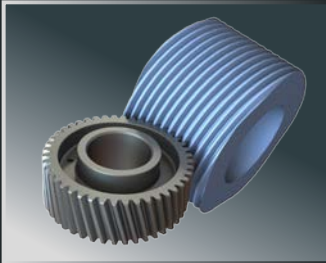

Generating Grinding

Maximum productivity at cutting speeds up to 100 m/s

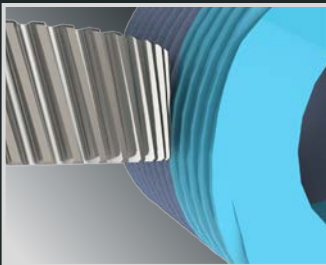

Polish Grinding (optional)

Efficient gearing through the use of segmented tools with a total width of 200 mm

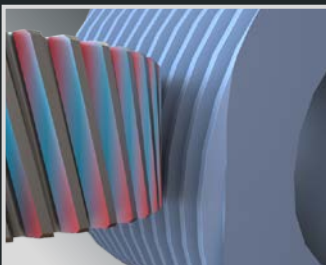

Topological Grinding (optional)

Grinding of twist-free tooth flanks as well as targeted twists, incl. Closed Loop processing

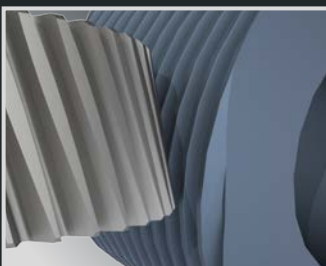

Beveloid Gearing (optional)

Grinding of beveloid gearing, with freely definable flank modifications as needed for improved running behavior and optimized load carrying capacity

Bevel Gear Technology for Mass-Production of Cylindrical Gears

Manufacturing cylindrical gears on a large scale – for Klingelberg, this meant taking technology and expertise from bevel gear production and applying it to the cylindrical gear industry. The result from the interdisciplinary development team is reflected in Speed Viper:

- Systematic linking of gear design and production
- Integration of Speed Viper into the Klingelberg production system
- Use of the Closed Loop system, which has been proven the world over for bevel gears, for cylindrical gears

Result:

Speed Viper uses bevel gear DNA for large-scale production of acoustically optimized cylindrical gears.

Speed Viper is fit for Industry 4.0

“The gear cutting industry is in transition” – and Klingelberg is poised to embrace the challenges ahead. The Speed Viper development team, consisting of engineers from the bevel gear and cylindrical gear product lines, has developed a unique machine design that combines know-how from the OERLIKON Bevel Gear Technology and HÖFLER Cylindrical Gear Technology brands. Thus Speed Viper combines outstanding grinding technology and an innovative operating concept with the unique Klingelberg Closed Loop process. The structural design of the machine is based on experiences gleaned from the successful C 30 and G 30 bevel gear machines as well as the VIPER 500 cylindrical gear machine. Speed Viper’s success factors include:

- High productivity through minimal productive time and auxiliary time
- High quality thanks to rugged mechanical engineering and the Klingelberg Closed Loop concept
- Maintenance-friendly machine design combined with expert service



HÖFLER generating grinding machine Speed Viper 300 with KOENIG CompactLoader



Innovative Machine Design for Maximum Productivity

- Cutting speeds up to 100 m/s
- Rugged machine design, made of vibration-damping cast polymer
- Optimal automation capability for minimal auxiliary times
- Use of long-life tools
- Compact design with minimal travel paths in the process
- Large dressing roll diameters for a long service life
- High-performance, aerodynamic nozzle for efficient coolant supply



Maximum Flexibility in the Grinding Process

- Speed Viper platform covers a broad range of components (large travel paths)
- Integrated, automated configuration of table drive parameter based on workpiece inertia
- Automatic tool clamping system for minimal set-up times
- Tool diameters between 210 mm and 320 mm
- Thermally stable machine design
- Flexible automation interface



Convenient, Intuitive Operating Concept

- Systematic linking of gear design and production
- Intuitive operator guidance through user-oriented operating concept and easy-to-follow menu design
- Modern control panel with 19-inch touchscreen display and clear screen layout
- Integration of Klingelnberg Closed Loop system
- Analysis, planning and control functions in parallel with production time, thanks to multitasking capability of Gear Operator software
- Machine configuration successfully completed in just a few steps



Easy, Fast and Service-friendly Maintenance

- Rugged design of machine components
- Pivoting control cabinet
- Logical arrangement of power supply
- Easy accessibility of modules to be serviced
- Real-time remote maintenance via Ethernet connection

HIGHLIGHTS



Acoustically Optimized Cylindrical Gears in Large-scale Production

- Linking of gear design with production for acoustically optimized gears
- Rugged machine base (large guide width) for minimal gearing deviations in the process
- Dynamically optimized drives
- Two-plane balancing system for minimal excitation in the process
- Systematic implementation of the Klingelnberg Closed Loop system, which provides feedback to the grinding machine about the manufactured quality



Closed Loop Quality Control in Line with Industry 4.0

- Central gearing and process design
- Networked connection in the Klingelnberg production system (GearEngine®)
- Knowledge management with central production data acquisition
- Digitization of gear production through automated machine correction



Energy Efficiency (e²) for Maximum Savings

- Flow-optimized coolant supply
- Pressure sensor on high-performance nozzle for fastest possible process start, as soon as adequate coolant is available
- On-demand optimization of drive control for permanent reduction of energy loss
- Systematic gear design with testing of producible geometries allows production of ultra-precise tooth geometries for optimized gear running behavior

Gear Operator – Process-oriented Operator Guidance with Wizard Technology

Powerful and Reliable

- Reproducible quality through central management of relevant tool and process parameters
- Maximum productivity through custom machining and loading cycles
- Workpiece and device-dependent axis drive optimization
- Process analysis and control in parallel with grinding using independently operated control and display pages
- Collision management based on a dynamic 3D machine model
- Automated quality control in Klingelberg Closed Loop system

Convenient and Clearly Laid-out

- Siemens Sinumerik 840 D SL control unit with 19-inch touchscreen display
- Intuitive user interface with process-oriented operator guidance
- Clarity through constantly visible menu structure and immediately responsive program logic
- Convenient setup with customized configuration of operating sequences
- Effective context-sensitive help with text, image and video material

Flexible and Expandable

Enhanced process reliability:

- Digital identification of tools and clamping fixtures
- Automatic allowance and stock removal control
- Contact monitoring during dressing

Service and maintenance:

- Remote maintenance via Klingelberg Service Gate
- Comprehensive machine and process analysis with Gear Analyzer
- Preventive maintenance with automatic axis test

Technologies:

- Finish grinding and polishing
- Topological grinding of specific twists
- Generation grinding of beveloid gearing



USER-FRIENDLY SOFTWARE CONCEPT

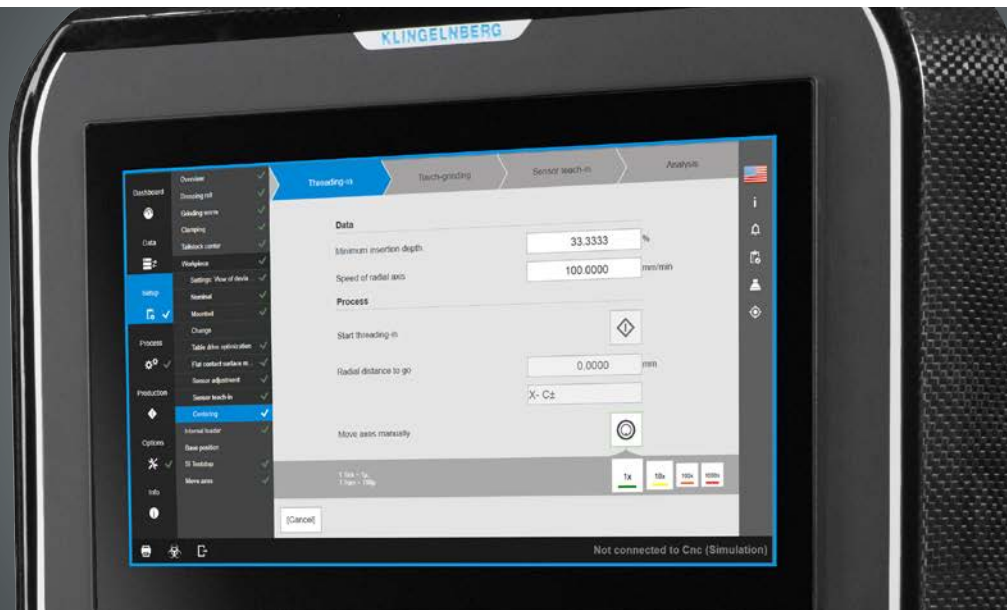

Real Productivity Gains with Gear Designer and Gear Operator

The quality demands on transmissions and gears continue to increase. Masking noises in the transmission environment – such as noise from the combustion engine – are diminishing or are being eliminated altogether as in the electric drive. Add to these the demands on transmission engineers to develop designs that are as resource-efficient as possible. Lightweight design and the use of low-viscosity transmission oil mean that gear quality must improve in order to achieve comparable or improved acoustic behavior.

In transmission and gear design, the use of calculation software for tooth contact analysis is commonplace. Optimization of gear modifications involves the elastic behavior of the shaft bearing system. In many cases, the gear geometry is optimized by simulating many variants, taking the tolerance fields into account. The objective of this variation calculation is to define a gear that is as rugged as possible.

Klingelberg has come up with a software package that draws on its successful production system for bevel gears. **Gear Designer** and **Gear Operator** are unique software solutions that were developed to implement the **Closed Loop process** for cylindrical gears.

The first **Closed Loop** is located at the interface between transmission calculation and production engineering.

Gear Designer imports the “function-oriented gear geometry” defined by the design engineer and carries out a production simulation. The resulting “production-ready gear geometry” is determined, taking the tool geometry and process kinematics into account. This is then analyzed and further optimized by the design engineer. Once the “process-ready gear geometry” has been approved, it is transferred to **GearEngine®** and the central management there. **Gear Operator** loads the data record and interactively assists machine operators in their tasks. In-series optimization of the gear geometry takes place via the **Closed Loop** quality control process. Gear variations are identified relative to the approved “production-ready gear geometry,” and the process is corrected accordingly. This follows the Klingelberg philosophy that has been used successfully in bevel gear production for many years.

Result: A virtual twin is created, which provides an achievable image for every process step. This makes it possible to clearly analyze deviations and identify the causes. It also eliminates uncertainties in the machine and cutter head setting and checking device with regard to the achievable quality and the quality actually achieved.

The Speed Viper Concept



Automotive Industry in Transition



“Electromobility” and “Industry 4.0” are hot topics currently under discussion in the automotive industry. As an automotive supplier, Klingelberg is also tackling these issues, in an effort to develop specific solutions for the demands of the future.

Demands on the automotive industry:

Owing to the characteristics of the speed-torque curve in the electric motor, it is possible to adapt the product range to suit the tractive power requirement curve in vehicles using fewer gears than is the case with the combustion engine. But industry professionals all agree that gear transmissions will continue to be indispensable, even in an electrified powertrain. This is necessary to meet requirements for driving comfort, efficiency and vehicle costs.

Current electric drive concepts for passenger cars frequently comprise of an electric motor with single-shift transmissions, consisting of two cylindrical gear stages or one planetary stage and one cylindrical gear stage. In light-weight commercial vehicles, concepts with up to two shifts are used, and the starting point in heavy-duty commercial vehicles is currently six to eight shifts, which are shifted automatically via the drive control based on the driving situation. The elimination of the internal combustion engine will lead not only to changes in transmis-

sion concepts, but also to significantly increased demands on the vibration and noise characteristics of the transmission. Whereas input speeds in IC engine-powered passenger cars do not exceed 6,000 rpm in most cases, motors with speeds significantly greater than 20,000 rpm are used in the electric powertrain. This brings gear runout and cumulative pitch errors – previously only significant as the cause of side bands or tooth mesh harmonics – into the acoustically relevant range.

Klingelberg solution:

With **GearEngine®** and its **Closed Loop** approach, Klingelberg has developed an exceptional solution for the process chain in cylindrical gear manufacturing. Owing to the quality-determining influence of hard finishing, the networking of Speed Viper with the Klingelberg Precision Measuring Centers is a crucial step in ensuring the quality of the production process. With the analysis options of the P machine software, particularly the waviness analysis option, the causes of noise problems can be quickly pinpointed. Thus the right tools are available for automotive gear production – and not just for electric powertrain transmissions.

Conclusion:

Klingelberg solutions deliver useful tools for gear production in the automotive industry of today and tomorrow, thus providing the right answers to questions arising in the areas of “electromobility” and “Industry 4.0”.



Commercial Vehicles



The developments in commercial, construction, and agricultural vehicles have never been as exciting: Specific industry solutions, payload optimization, sophisticated safety systems and not least fuel efficiency are just a few of the key trends. Each new vehicle generation must fulfill the requirement of providing more safety and comfort while achieving lower total overall operating costs. The use of Klingelberg solutions makes it possible to mass-produce cylindrical gears with the required quality.

Contract Gear Manufacturers



Contract gear manufacturers in particular have to be able to react flexibly to market conditions on a daily basis and produce a whole host of different gear components. From standard solutions to high-tech applications – Klingelberg offers its customers tailor-made machine designs. These are supplemented by comprehensive engineering and other services, including everything from in-house machine certification at Klingelberg, to machine-attendant and software training, right through to production support.

Industrial Gear Units



The industrial gear unit sector comprises many different applications, all of which place great demands on the reliability of gear wheels. The cylindrical gears for these sectors are often produced by companies specializing in small batch sizes and a variety of products. A rigid machine design and flexible, cost-effective tool systems are the keys to success for ranking among the market leaders in these sectors.

Robot Industry



Digitization, automation, and robotics are key issues in mechanical and plant engineering. From the autonomous lawn-mower to the articulated robot in the operating room: In addition to sophisticated software, every robot runs on high-precision hardware – and that starts with the smallest toothed gear. With Klingelberg system solutions for cylindrical and bevel gears, the right “mechanical backbone” for every robot type can be built in the smaller diameter ranges.

TECHNICAL DATA

	SPEED VIPER 300	SPEED VIPER 180	SPEED VIPER ² 180	SPEED VIPER ² 80
Workpiece diameter (max.)	Ø 300 mm	Ø 180 mm	Ø 180 mm	Ø 80 mm
Grinding stroke	500 mm			
Work area over table (min. – max.)	0 – 500 mm			
Distance between center above table (min. – max.)	300 – 1,100 mm		295 – 895 mm	
Module (min. – max.)	0.5 - 5 mm	0.5 - 3 mm		
Swivel angle	+/- 45°			
Grinding worm diameter	Ø 320 - 210 mm			
Grinding worm width (max.)	200 mm			
Grinding spindle	25 kW			
Grinding worm speed	7,200 rpm			
Cutting speed	100 m/s			
Table diameter	Ø 180 mm	Ø 120 mm		
Table load (max.)	50 kg	35 kg		
Table hole (diameter x depth)	Ø 87 x 196 mm	Ø 59 x 150 mm		
Table rotation speed (max.)	2,300 rpm	3,000 rpm		
Axial feed rate	12,000 mm/min			
Radial feed rate	18,000 mm/min			
Tangential feed rate	9,000 mm/min			
Total connected load	60 kVA			
Machine dimensions (L x W x H)	approx. 3,085 x 2,160 x 3,420 mm		approx. 3,455 x 2,160 x 3,420 mm	
Filter unit dimensions (L x W)	approx. 3,400 x 2,160 mm			
Net weight	approx. 15,000 kg		approx. 18,000 kg	

Installation Dimensions

SPEED VIPER 300/180: FRONT VIEW

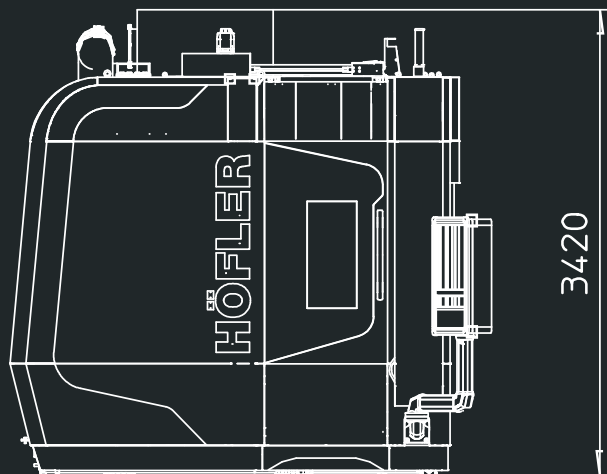

SPEED VIPER 300/180: TOP VIEW

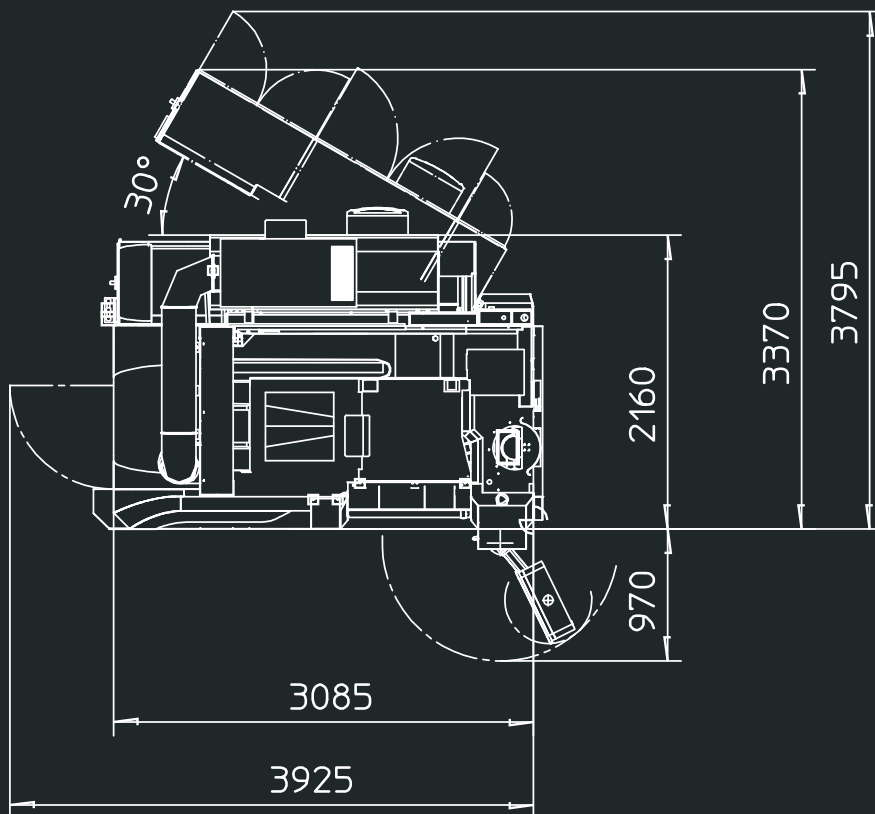

All dimensions in mm

KLINGELNBERG Service

The KLINGELNBERG Group is a world leader in the development and manufacture of machines for bevel gear and cylindrical gear production, and precision measuring centers for gearing and axially symmetrical components, as well as the production of customized high-precision drive components. In addition to the headquarters in Zurich, Switzerland, further development and production facilities are located in Hückeswagen and Ettlingen, Germany.

The company also maintains a presence with Sales and Service offices and numerous marketing agents. On this basis, KlingelInberg offers users a comprehensive range of services for all aspects of toothed gear design, manufacturing, and quality inspection. The spectrum includes technical consulting, on-site machine acceptance, operator and software training as well as maintenance contracts.

KLINGELNBERG Solutions

KlingelInberg solutions are used in the automotive, commercial vehicle, and aviation industries, as well as in shipbuilding, the wind power industry, and the general transmission manufacturing industry. With numerous R&D engineers around the globe and over 200 registered patents, the company consistently demonstrates its capacity for innovation.

EN 03/2024 - Subject to technical modifications without notice.

FOLLOW US AND STAY UP TO DATE:



KLINGELNBERG AG

Binzmühlestrasse 171
8050 Zürich, Switzerland
Fon: +41 44 278 7979
Fax: +41 44 273 1594

KLINGELNBERG GmbH

Peterstraße 45
42499 Hückeswagen, Germany
Fon: +49 2192 81-0
Fax: +49 2192 81-200

KLINGELNBERG GmbH

Industriestraße 5-9
76275 Ettlingen, Germany
Fon: +49 7243 599-0
Fax: +49 7243 599-165

You can also find your local contact for sales advice at <https://klingelInberg.com/en/contact>